

## ADDITIONAL TECHNICAL INFORMATION:

Panamax MB1000 is intended to be installed in a dry indoor environment with a maximum ambient temperature of 0 – 40°C (32 – 104°F) and that is free of conductive contaminants.

## NOTICE TO SERVICE PERSONNEL ONLY:

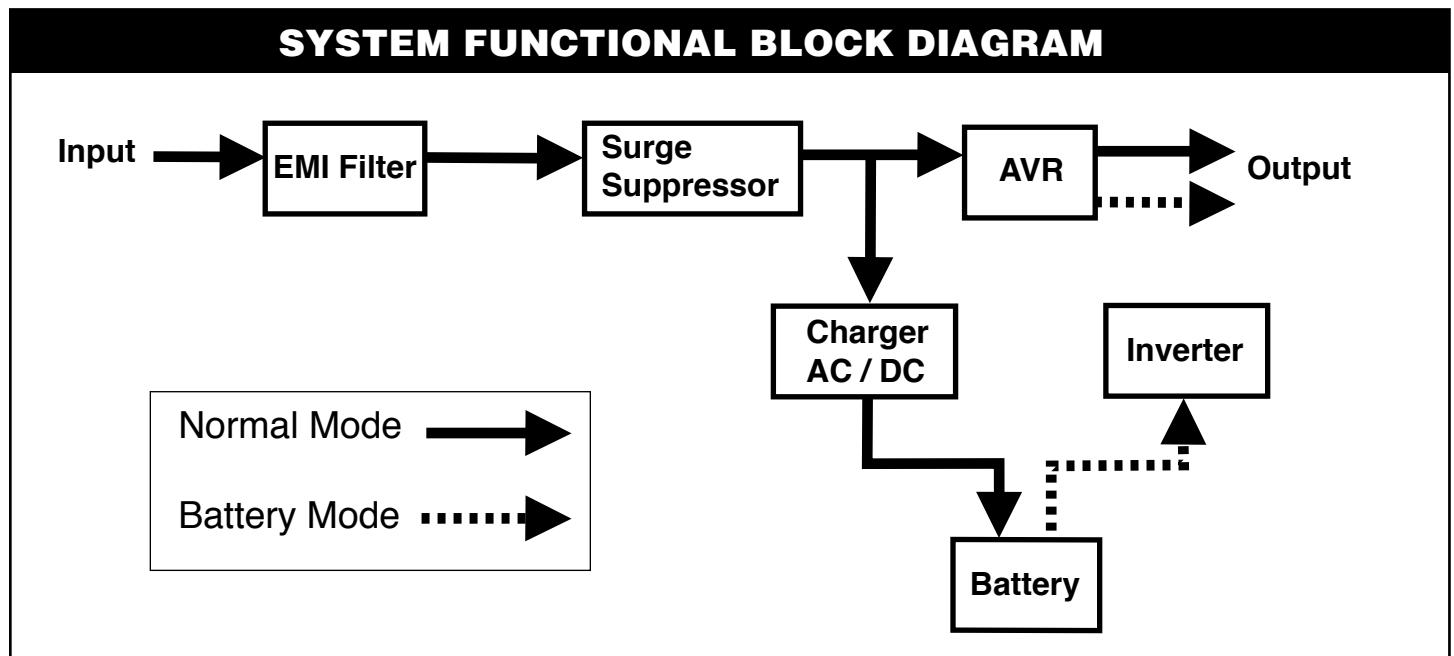

When replacing batteries, replace the two batteries with the following:

BB Battery, Part Number **SH7-12**, rated **12V, 28W**

**CAUTION:** RISK OF ENERGY HAZARD: 12V, maximum 9 Ampere-hour batteries. Before replacing batteries, remove conductive jewelry such as chains, wrist watches and rings. High energy through conductive materials could cause severe burns.

**CAUTION:** DO NOT dispose of batteries in a fire. The batteries may explode.

**CAUTION:** DO NOT open or mutilate batteries. Released material is harmful to the skin and eyes and may be toxic.

**PANAMAX**<sup>®</sup>